

LevelCheck 510

Microwave barrier and contactless level monitoring of bulk materials



NEW: ATEX option



Application

The **microwave barrier** LevelCheck 510 is designed for **level monitoring of solids in silos, container, bunkers, crushers, shafts etc.** It can monitor min/max levels, ensure continuous supply and prevent overfilling.

The LevelCheck 510 can also be used to **detect jamming on conveyor belts, count goods, position items or hedge dangerous areas.** The device is robust, easy to install and is not affected by dirt, dust or steam.

Scope of use

Animal feed industry
 Building materials
 Cement industry
 Ceramics
 Chemical industry
 Detergent industry
 Food industry
 Glass production
 Metal production
 Minerals and Mining

Pharmaceuticals
 Pigment production
 Power plants
 Pulp and paper
 Recycling industry
 Synthetic materials
 Textiles
 Waste incineration
 etc.

HUMY 300/3000

Continuous inline moisture measurement

MF 3000

Microwave mass flow measurement

FS 510

Microwave material flow monitoring

FS 600

Electrostatic material flow monitoring

FS 710/710/750

Triboelectric dust monitoring

LC 510

Microwave barrier and limit level monitoring

Main Benefits

- Reliable, contactless microwave technology
- Up to 25 meters distance between emitter and receiver possible
- Is not affected by dirt, dust or steam
- Does not interfere with the material
- Very flexible with adjustable amplification, filter, hysteresis and delay
- Compact and easy to install and retrofit
- Robust stainless-steel design
- Wear- and maintenance-free
- 100% safe operation with active self-monitoring
- ATEX protection (optional up to zone 20/21)

Function

The LevelCheck LC 510 is based on the newest microwave technology. An emitter sends out a low-power microwave beam which is received by an opposite device. The two devices can be placed up to 25 meters apart. Any material between them is detected and a switching process started. This allows e.g. to monitor minimum / maximum fill levels in silos or detect objects entering or leaving the microwave barrier.

The measurement is contact-free and does not impact the bulk material. All settings like amplification, filter, hysteresis, delay can be adjusted, making the system very flexible. Optional versions for ATEX up to zone 20/21 and pressure up to 30-60 bar extend its area of use. The LevelCheck LC 510 is compact and is installed within minutes.

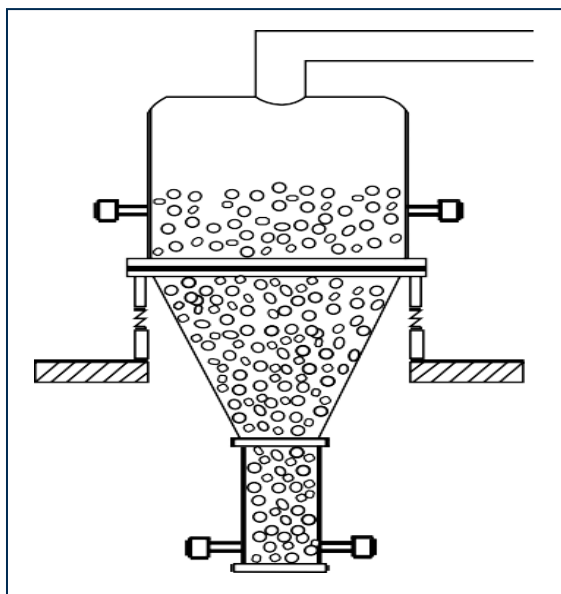

Technical Data

Housing material	Stainless steel (1.4307)
Sensor surface	Teflon (optional ceramic)
Ambient temperature	-20°C to +60°C
Process temperature	-20°C to +85°C
Process pressure	6 bar (optional 30-60 bar)
Protection class	IP65
Ex protection / ATEX	Optional up to Zone 20/21
Power supply	24 VDC (18 - 30 VDC)
Current consumption	Ca. 80 mA at 24 VDC
Transmitting power	10 dBm
Output (switching)	1x Relay contact (change-over contact, potential free) 1x NO ready contact
Switching voltage	30 VAC or 30 VDC
Switching current	min. 10 µA & max. 2 A
Switching power	30 VA or 30 W
Electr. connection	Plug-in screw terminals
Adjustable parameter	Amplification, filter, hysteresis, delay
Parameterization	Direct at device via buttons
Indicators	LED green (working) LED yellow (switch) Bar graph (e.g. field intensity)

The LC 510 is the most robust microwave barrier of its class - made of stainless steel, optimized for a long lifetime and wear- and maintenance-free.

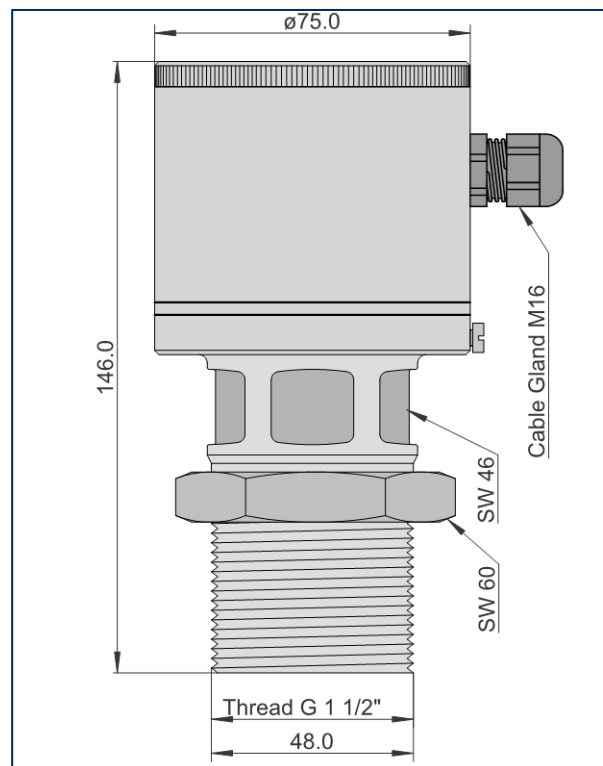

Mütec Instruments – Your safe choice