



# Overview electromagnetic flow measurement

## Description

The electromagnetic flow meters are ideally suited for flow measurement of all liquids with a minimum conductivity of  $5 \mu\text{S/cm}$  ( $20 \mu\text{S/cm}$  for demineralized water). These meters are very accurate and the flow measurement is independent of density, temperature and pressure of the medium.

## Applications

There is almost no limit to the applications of electromagnetic flow meters, which are ideally suited for:

- No mounting restrictions
- Large flow range (0,003 – 55430 m<sup>3</sup>/h)
- Short upstream and downstream straight run mounting distances
- Wide temperature range (-20°C up to max. 150°C)
- Suitable for high viscosities
- Line pressure up to max. PN 100

Magnetoflow<sup>®</sup> meters serve industrial applications (like chemical process, food & beverage, pharmacy, pulp and paper, metal and mining, automotive industry, photography and textile) as well as water and waste water applications like water supply, water and sludge discharge and water treatment plants with success and growing market share.

Electromagnetic flow meters can handle applications that other measuring principles cannot handle due to tough hydraulic setups, solid particle content, high viscosities and aggressive fluids.



## Measuring principle

The operating principle of the electromagnetic flow meter is based on Faraday's law of magnetic induction: The voltage induced across any conductor, as it moves at right angles through a magnetic field, is proportional to the velocity of that conductor. The voltage induced within the fluid is measured by two diametrically opposed mounted electrodes. The induced signal voltage is proportional to the magnetic flux density, the distance between the electrodes and the average flow velocity of the fluid.

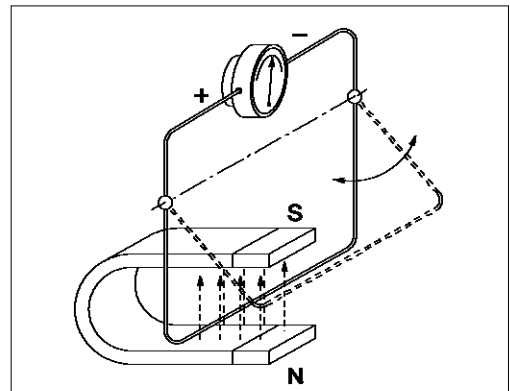



## Amplifiers

### Type ModMAG™ M2000

The amplifier type M2000 is best suited for bidirectional flow measurement of fluids with a conductivity  $> 5 \mu\text{S}/\text{cm}$  ( $> 20 \mu\text{S}/\text{cm}$  for demineralized water). M2000 shows a high accuracy, is easy to use and can be chosen for a large and flexible applications spectrum. The backlit, four-line display shows all actual flow measuring data, daily and complete information, including alarm messages. The standard amplifier has 4 programmable digital outputs, one digital input, power output and USB interface. Integrated test tools make the putting into operation and the service easier.



### Type ModMAG™ M1000 / M1500

The basic line of M1000 is provided with 24 VDC power supply, without display, with passive outputs and can be programmed via a serial port RS232 or separate handheld. The device can be factory preconfigured and then just needs to be electrically connected on site. The M1000 is encased into a powder-coated aluminium diecast housing IP65 and has two M 20 screws. The basic line can be provided with a four-line LC display, a 115/230 VAC power supply and active pulse and analog outputs. The standard model M1000 is supplied with an analog output, two digital outputs for pulse and frequency as well as a digital input. With an accuracy of  $\pm 0,5\%$  of actual flow ( $> 0,5 \text{ m/s}$ ) and flow measurements ranging between 0,03 and 12 m/s in both directions, the flow meter covers a great variety of applications.

### Type ModMAG™ M3000/M4000

The amplifier with modular design allows flow measurements in ex-zones 1 and 2, in either the mounted or remote version. The amplifier housing, made of powder-coated aluminium, is available in protection class IP67 and with a separate connection space. Programming can be done either with closed housing thanks to a magnetic pen or with open housing via three buttons. The four-line display shows all necessary data like actual flow, totalizer and status messages. The programmable excitation frequency even enables the amplifier to be adjusted for difficult metering applications. The new developed process for amplifier compensation enables a high accuracy, especially in the lower flow range.





## Detectors

### Type II

The electromagnetic detector type II is not only available in a number of different flange process connections (DIN, ANSI, JIS, AWWA, etc.) but also in a number of liners like hard rubber, soft rubber, PTFE, PFA or Halar. Available in sizes from DN 6 to DN 1400 and nominal pressures up to PN 100, the detector type II is best suited for a variety of applications in the industry and the water/waste water industry.

Flange process connection



Wafer connection



### Type III

Thanks to its very short lay length, the detector type III is often the right alternative to a lot of applications. Delivered with a PTFE liner, the detector type III has a standard nominal pressure of PN 40.

### Type Food

The sanitary detector was developed for the flow measurement of liquid food. This model is available with Tri-Clamp®, DIN 11851 process connections and also with any special connections (customer specifications). The sanitary detector is delivered in a stainless steel housing and with PTFE lining.

Process connections Tri-Clamp®, DIN 11851, etc.





## Selection of electromagnetic detectors

### Flow rates

| DN   | Size   | Flow range |            |            |            | Detector type |     |      |
|------|--------|------------|------------|------------|------------|---------------|-----|------|
|      |        | 0,03 m/s   | 0,5 m/s    | 2,5 m/s    | 12 m/s     | II            | III | Food |
| 6    | 1/4"   | 0,05 l/min | 0,85 l/min | 4,2 l/min  | 20 l/min   | ★             |     |      |
| 8    | 3/10"  | 0,09 l/min | 1,5 l/min  | 7,5 l/min  | 36 l/min   | ★             |     |      |
| 10   | 3/8"   | 0,14 l/min | 2,4 l/min  | 12 l/min   | 57 l/min   | ★             |     | ★    |
| 15   | 1/2"   | 0,32 l/min | 5,3 l/min  | 27 l/min   | 127 l/min  | ★             |     | ★    |
| 20   | 3/4"   | 0,57 l/min | 9,4 l/min  | 47 l/min   | 226 l/min  | ★             |     | ★    |
| 25   | 1.0"   | 0,88 l/min | 15 l/min   | 74 l/min   | 353 l/min  | ★             | ★   | ★    |
| 32   | 1 1/4" | 1,45 l/min | 24 l/min   | 121 l/min  | 579 l/min  | ★             | ★   | ★    |
| 40   | 1.5"   | 2,3 l/min  | 38 l/min   | 188 l/min  | 905 l/min  | ★             | ★   | ★    |
| 50   | 2.0"   | 3,5 l/min  | 59 l/min   | 295 l/min  | 1414 l/min | ★             | ★   | ★    |
| 65   | 2 1/2" | 6,0 l/min  | 100 l/min  | 498 l/min  | 2389 l/min | ★             | ★   | ★    |
| 80   | 3"     | 9,0 l/min  | 151 l/min  | 754 l/min  | 3619 l/min | ★             | ★   | ★    |
| 100  | 4"     | 14 l/min   | 236 l/min  | 1178 l/min | 5655 l/min | ★             | ★   | ★    |
| 125  | 5"     | 1,33 m³/h  | 22 m³/h    | 110 m³/h   | 530 m³/h   | ★             |     |      |
| 150  | 6"     | 1,9 m³/h   | 32 m³/h    | 159 m³/h   | 763 m³/h   | ★             |     |      |
| 200  | 8"     | 3,4 m³/h   | 57 m³/h    | 283 m³/h   | 1357 m³/h  | ★             |     |      |
| 250  | 10"    | 5,3 m³/h   | 88 m³/h    | 442 m³/h   | 2121 m³/h  | ★             |     |      |
| 300  | 12"    | 7,6 m³/h   | 127 m³/h   | 636 m³/h   | 3054 m³/h  | ★             |     |      |
| 350  | 14"    | 10,4 m³/h  | 173 m³/h   | 866 m³/h   | 4156 m³/h  | ★             |     |      |
| 400  | 16"    | 14 m³/h    | 226 m³/h   | 1131 m³/h  | 5429 m³/h  | ★             |     |      |
| 450  | 18"    | 17 m³/h    | 286 m³/h   | 1431 m³/h  | 6870 m³/h  | ★             |     |      |
| 500  | 20"    | 21 m³/h    | 353 m³/h   | 1767 m³/h  | 8482 m³/h  | ★             |     |      |
| 600  | 24"    | 31 m³/h    | 509 m³/h   | 2545 m³/h  | 12214 m³/h | ★             |     |      |
| 700  | 28"    | 42 m³/h    | 693 m³/h   | 3464 m³/h  | 16625 m³/h | ★             |     |      |
| 800  | 32"    | 54 m³/h    | 905 m³/h   | 4524 m³/h  | 21714 m³/h | ★             |     |      |
| 900  | 36"    | 69 m³/h    | 1145 m³/h  | 5725 m³/h  | 27482 m³/h | ★             |     |      |
| 1000 | 40"    | 85 m³/h    | 1414 m³/h  | 7068 m³/h  | 33928 m³/h | ★             |     |      |
| 1200 | 48"    | 122 m³/h   | 2036 m³/h  | 10178 m³/h | 48857 m³/h | ★             |     |      |
| 1400 | 56"    | 166 m³/h   | 2771 m³/h  | 13854 m³/h | 66499 m³/h | ★             |     |      |