



## VSJ Pipe Mounting Bands for Submersible Sensors



Use optional VSJ stainless steel Pipe Mounting Bands for easy Sensor installation in round pipes.

Each Pipe Band includes:

- Band Adjustment Jack allowing  $\pm 0.5"$  (13 mm) adjustment from the nominal band size.  
Note: VSJ6 and VSJ8 bands do not include adjustment jacks - they secure to pipe by spring tension.
- Stainless steel bracket for Sensor mounting
- Pre-drilled for tie wraps (included) to secure Sensor cable

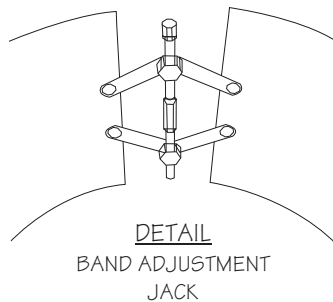

<u>CODE</u>	<u>BAND SIZE</u>
VSJ6	6"/150 mm ID pipes (without adjustment jack)
VSJ8	8"/200 mm ID pipes (without adjustment jack)
VSJ10	10"/250 mm ID pipes
VSJ12	12"/300 mm ID pipes
VSJ14	14"/350 mm ID pipes
VSJ15	15"/375 mm ID pipes
VSJ16	16"/400 mm ID pipes
VSJ18	18"/450 mm ID pipes
VSJ20	20"/500 mm ID pipes
VSJ24	24"/600 mm ID pipes
VSJ30	30"/750 mm ID pipes

### Mounting Instructions:

Install the stainless steel pipe band with the sensor mounting bracket at the invert (bottom) of the pipe. Ensure that the sensor bracket is parallel to the water surface (check with a level). Mount so the tapered end of the sensor will point upstream and the sensor cable will point downstream. Turn the  $\frac{1}{4}"$  hex nut clockwise to expand the bracket and secure to the pipe wall by friction fit.

Insert the sensor into the mounting bracket and clip or tie wrap the sensor cable securely to the stainless steel pipe band.

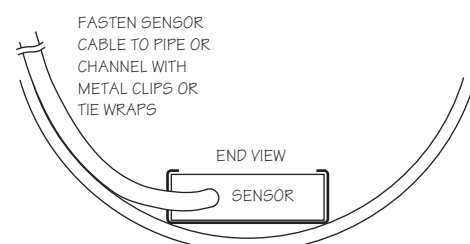
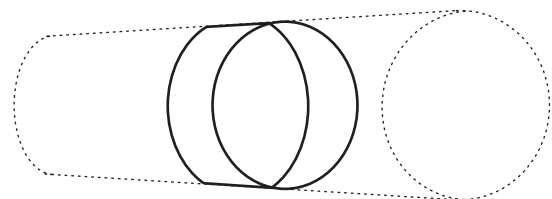



## VSJ Half-Pipe Mounting Bands for Submersible Sensors

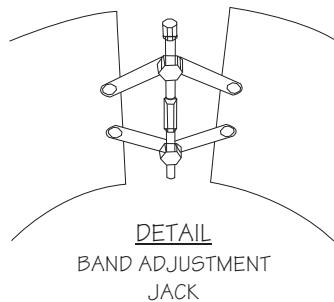

Use optional VSJ stainless steel Half-Pipe Mounting Bands for easy Sensor installation in large round pipes.

Each VSJ Pipe Band assembly includes:

- Stainless Steel Band
- Band Adjustment Jack
- End Brackets (2)
- Stainless steel bracket for Sensor mounting
- Pre-drilled for tie wraps (included) to secure Sensor cable

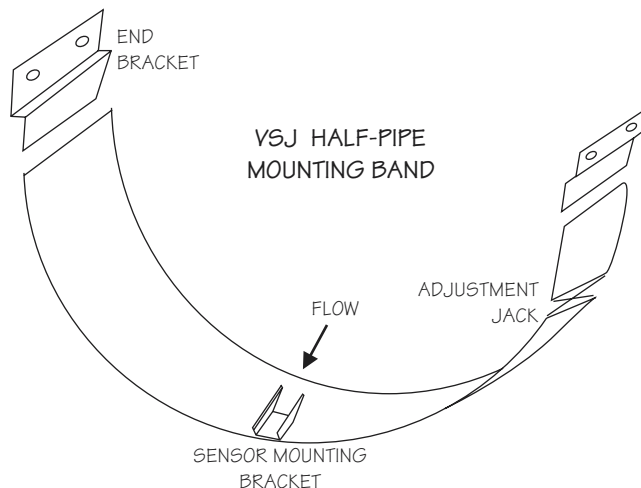

<b>CODE</b>	<b>BAND SIZE</b>
VSJ32-40	32-40" / 800-1000 mm ID pipes
VSJ42-54	42-54" / 1100-1375 mm ID pipes
VSJ56-72	56-72" / 1400-1800 mm ID pipes

### Mounting Instructions:

Install the stainless steel half-pipe band with the sensor mounting bracket at the invert (bottom) center of the pipe.

Turn the 1/4" hex nut of the band jack counter-clockwise to minimize the band length and then mount the two end brackets on the pipe wall. Install the pipe band and expand the adjustment jack to secure the band.

Ensure that the sensor bracket is parallel to the water surface (check with a level). Mount so the tapered end of the sensor will point upstream and the sensor cable will point downstream. Turn the 1/4" hex nut clockwise to expand the bracket and secure to the pipe wall by friction fit.

Insert the sensor into the mounting bracket and clip or tie wrap the sensor cable securely to the stainless steel pipe band.

