



Electromagnetic amplifier ModMAG™ M1500 for all detectors



Features

- Accuracy $\pm 0,5\%$
- Flow range 0,03 - 12 m/s
- DN6 - DN200
- With LCD display
- Power supply 24 VDC/ 115 VAC/ 230 VAC

Description

The basic line of M1500 is provided with 24 VDC power supply, display, passive outputs and can be programmed via a serial port RS232 or 3 buttons. The device can be factory preconfigured and then just needs to be electrically connected on site. The M1500 is encased into a powder-coated aluminium diecast housing IP65 and has two M 20 screws. The basic line can be provided with a four-line LC display, a 115/230 VAC power supply and active pulse and analog outputs. The standard model M1500 is supplied with an analog output, two digital outputs for pulse and frequency as well as a digital input. With an accuracy of $\pm 0,5\%$ of actual flow ($>0,5$ m/s) and flow measurements ranging between 0,03 and 12 m/s in both directions, the flow meter covers a great variety of applications.

Measuring principle

The operating principle of the electromagnetic flow meter is based on Faraday's law of magnetic induction: The voltage induced across any conductor, as it moves at right angles through a magnetic field, is proportional to the velocity of that conductor. The voltage induced within the fluid is measured by two diametrically opposed internally mounted electrodes. The induced signal voltage is proportional to the product of the magnetic flux density, the distance between the electrodes and the average flow velocity of the fluid.

Applications

The M1500 has been designed especially for applications in machinery plants, vehicles and batching processes. The applications range from DN 6 to DN 200 with the most various process connections like DIN flanges, dairy pipe connections, TriClamp®, etc.

Dimensions

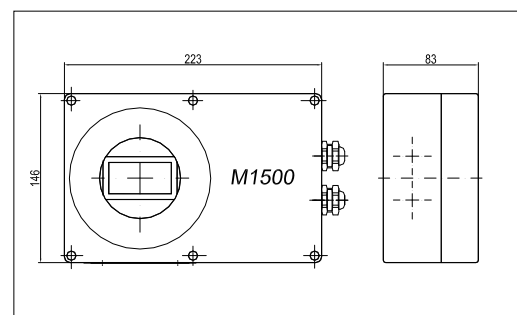



Technical Data

Power supply	24 VDC optional 115 / 230 VAC (50 / 60 Hz), 10 VA
Accuracy	±0,5% of actual flow, ≥0,5 m/s ±2,5 mm/s of actual flow, <0,5 m/s
Repeatability	<0,1% of full scale
Flow range	0,03 – 12 m/s
Conductivity	min. 5 µS/cm (20 µS/cm for demineralized water)
Flow direction	bi-directional
Programming	with LCD, 4 lines / 16 characters, backlit, actual flow, 3 totalizers, status display
Interface	RS232 or via 3 buttons
Analog output	RS232 for measuring values and programming
Pulse output	4 - 20 mA passive, optional active, flow direction is displayed upon a separate status output
Frequency output	passive, optional active, 2 open collectors, passive 24 VDC, 50 mA, max. 10 kHz
Status output	max. 10 kHz (open collector)
Empty pipe detection	min./max. alarm, preselection, flow direction, error message, free configurable
Low flow cut off	separate electrode
Housing	0-10%
Protection class	Powder coated aluminium die cast
Cable insertion	IP65
Ambient temperature	2 x M 20 -20 up to +60°C

Detector type III

Wafer connection

Wall mounted

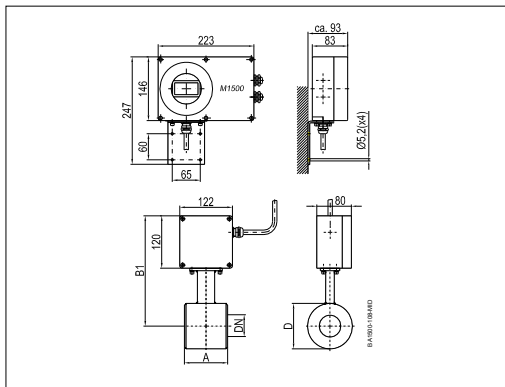

Remote version

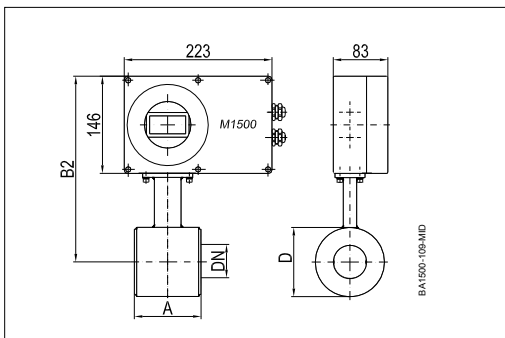

Thanks to its very short lay length, the detector type III is often the right alternative to a lot of applications. Delivered with a PTFE liner, the detector type III has a standard nominal pressure of PN 40.

Technical Data

Size	DN 25 – 100 (1" ... 4")	
Process connection	Wafer connection (in-between flange mounting)	
Nominal pressure	PN 40	
Protection class	IP65, optional IP68	
Min. conductivity	5 µS/cm (20 µS/cm (for demineralized water)	
Liner materials	PTFE	-40°C to +150°C
Elektrodes material	Hastelloy C (Standard)	
	Tantal	
	Platinum / Gold plated	
	Platinum / Rhodium	
Housing	Carbon steel / optional stainless steel	
Lay length	DN 25 – 50	100 mm
	DN 65 – 100	150 mm

Dimensions (mm)

DN		A	B1	B2	D
25	1"	100	238	201	74
32	1 ¼"	100	243	206	84
40	1 ½"	100	248	211	94
50	2"	100	253	216	104
65	2	150	266	229	129
	½"				
80	3"	150	271	234	140
100	4"	150	279	242	156
PN 40					



Detector type II

Flange process connection

Wall mounted

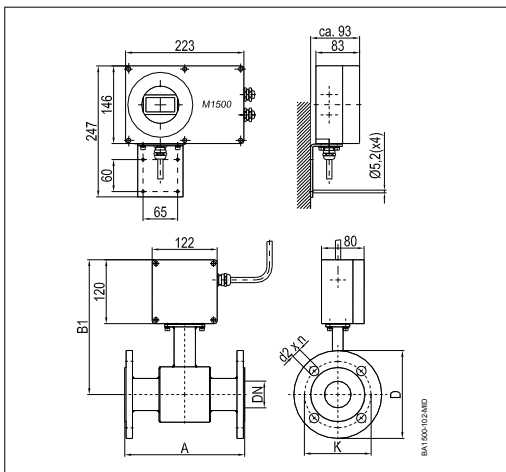

The electromagnetic detector type II is not only available in a number of different flange process connections (DIN, ANSI, JIS, AWWA, etc.) but also in a number of liners like hard rubber, soft rubber, PTFE, PFA or Halar. Available in sizes from DN 6 to DN 200 and nominal pressures up to PN 100, the detector type II is best suited for a variety of applications in the industry and the water/waste water industry.

Technical Data

Size	DN 6 – 200 (1/4" ... 8")		
Process connection	Flange: DIN, ANSI, JIS, AWWA, etc.		
Nominal pressure	up to PN 100		
Protection class	IP65, optional IP68		
Min. conductivity	5 $\mu\text{S}/\text{cm}$ (20 $\mu\text{S}/\text{cm}$ (for demineralized water))		
Linear materials	Hard/ soft rubber	from DN 25	0 up to +80°C
	PFA	DN 6 – 10	-40 up to +150°C
	PTFE	DN 15 – 200	-40 up to +150°C
Electrodes materials	Hastelloy C (Standard), Tantal Platinum / Gold plated, Platinum / Rhodium		
Housing	Carbon steel / Optional stainless steel		
Lay length	DN 6 – 20	170 mm	
	DN 25 – 50	225 mm	
	DN 65 – 100	280 mm	
	DN 125 – 200	400 mm	

Remote version

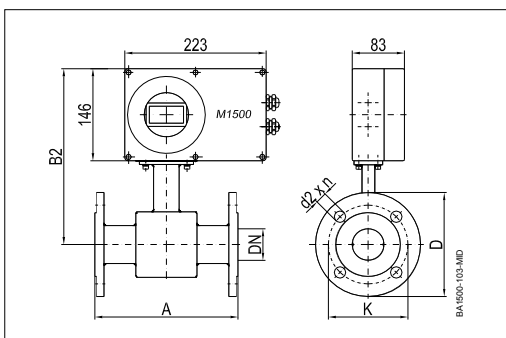

Dimensions (mm)

DN		A Std*	A ISO**	B1	B2	with ANSI-flanges			with DIN-flanges		
						Ø D	Ø K	Ø d2xn	Ø D	Ø K	Ø d2xn
6	1/4"	170	---	228	191	88,9	60,3	15,9 x 4	90	60	14 x 4
8	3/10"	170	---	228	191	88,9	60,3	15,9 x 4	90	60	14 x 4
10	3/8"	170	---	228	191	88,9	60,3	15,9 x 4	90	60	14 x 4
15	1/2"	170	200	238	201	88,9	60,3	15,9 x 4	95	65	14 x 4
20	3/4"	170	200	238	201	98,4	69,8	15,9 x 4	105	75	14 x 4
25	1"	225	200	238	201	107,9	79,4	15,9 x 4	115	85	14 x 4
32	1 1/4"	225	200	253	216	117,5	88,9	15,9 x 4	140	100	18 x 4
40	1 1/2"	225	200	253	216	127	98,4	15,9 x 4	150	110	18 x 4
50	2"	225	200	253	216	152,4	120,6	19 x 4	165	125	18 x 4
65	2 1/2"	280	200	271	234	177,8	139,7	19 x 4	185	145	18 x 4
80	3"	280	200	271	234	190,5	152,4	19 x 4	200	160	18 x 8
100	4"	280	250	278	241	228,6	190,5	19 x 8	220	180	18 x 8
125	5"	400	250	298	261	254	215,9	22,2 x 8	250	210	18 x 8
150	6"	400	300	310	273	279,4	241,3	22,2 x 8	285	240	22 x 8
200	8"	400	350	338	301	342,9	298,4	22,2 x 8	340	295	22 x 12
Standard											
with ANSI-flanges						from DN 6 - 200			LBS 150		
with DIN flanges						from DN 6 - 200			PN 16		
* Standard **ISO 13359											



Sanitary detector for food

Process connections Tri-Clamp®, DIN 11851, ISO 2852, etc.

TriClamp®, wall mounted

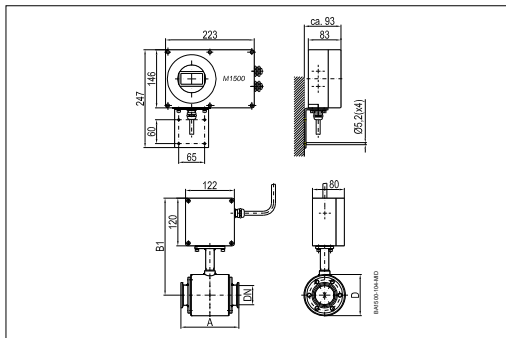

The sanitary detector was developed for the flow measurement of liquid food. This model is available with Tri-Clamp®, DIN 11851, ISO 2852 process connections and also with any special connections (customer specifications). The sanitary detector is delivered in a stainless steel housing and with PTFE lining.

Technical data

Size	DN 10 - 100 (3/8" ... 4")	
Process connections	Tri-Clamp®, DIN 11851, ISO 2852, etc.	
Nominal pressure	PN 10/16	
Protection class	IP65, optional IP68	
Min. conductivity	5 µS/cm (20 µS/cm for demineralized water)	
Liner materials	PTFE	PTFE
Electrodes materials	Hastelloy C (Standard) Tantal Platinum / Gold plated Platinum / Rhodium	
Housing	Stainless steel	
Lay length	Tri-Clamp® connection	DN 10 - 50 : 145 mm DN 65 - 100 : 200 mm
	DIN 11851 connection	DN 10 - 20 : 170 mm DN 25 - 50 : 225 mm DN 65 - 100 : 280 mm

TriClamp®, remote version

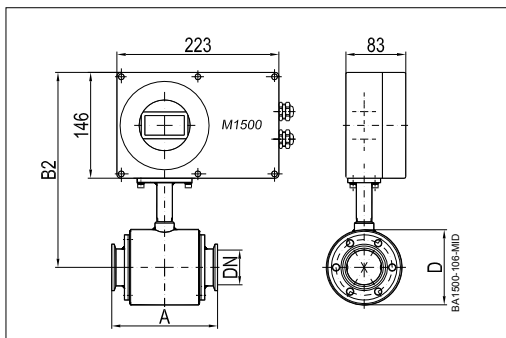

Dimensions (mm) type Food Tri-Clamp®

DN		A	B1	B2	D
10	3/8"	145	228	191	74
15	1/2"	145	228	191	74
20	3/4"	145	228	191	74
25	1"	145	228	191	74
40	1 1/2"	145	238	201	94
50	2"	145	243	206	104
65	2 1/2"	200	256	219	129
80	3"	200	261	224	140
100	4"	200	269	232	156
PN 10					

DIN11851, wall mounted

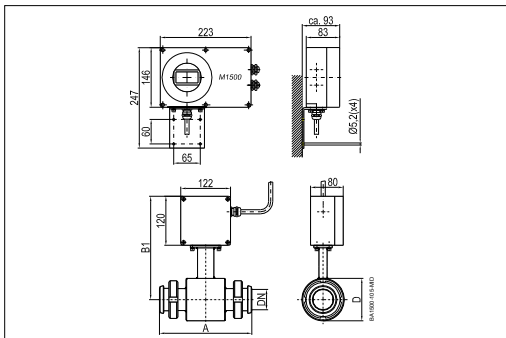

Dimensions (mm) type Food DIN 11851

DN		A	B1	B2	D
10	3/8"	170	238	201	74
15	1/2"	170	238	201	74
20	3/4"	170	238	201	74
25	1"	225	238	201	74
32	1 1/4"	225	243	206	84
40	1 1/2"	225	248	211	94
50	2"	225	253	216	104
65	2 1/2"	280	266	229	129
80	3"	280	271	234	140
100	4"	280	279	242	156
PN 16					

DIN 11851, remote version

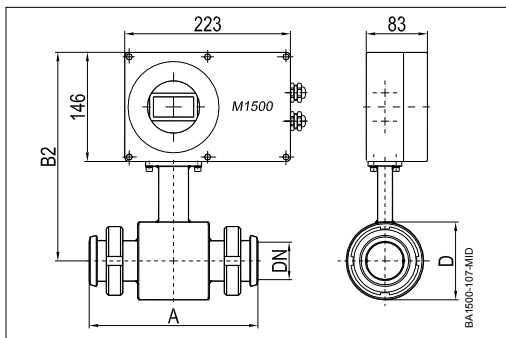

paab

TEKNO TRADING

Paab Tekno Trading AB - Tingvallastrand 12, 661 40 Säffle, Sweden
Tel: +46 533 150 60 - Fax +46 533 169 31 - info@paab.com - www.paab.com